

STRADDLE MOUNT

WITH MOUNTING EAR TYPE

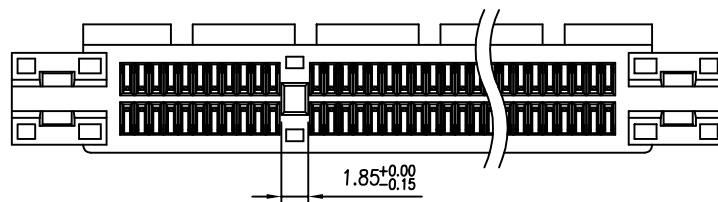
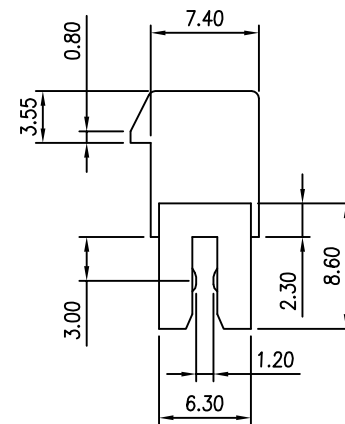
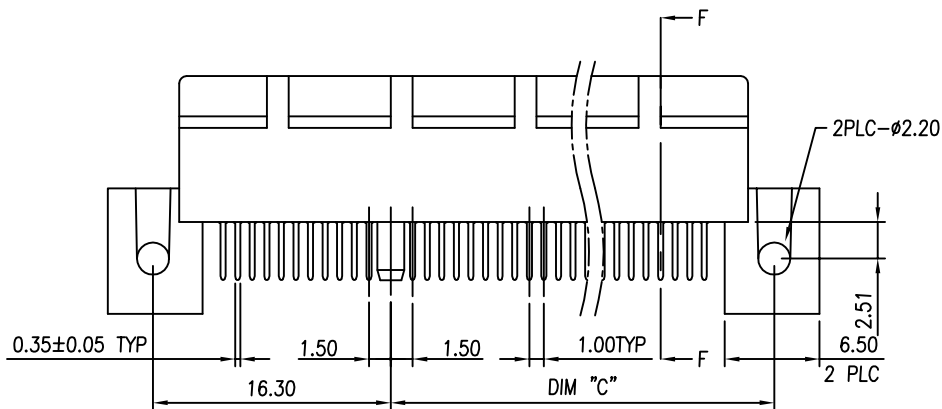
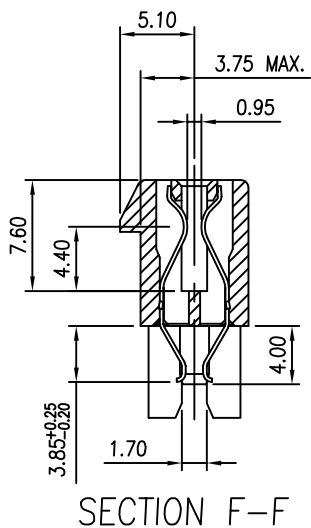
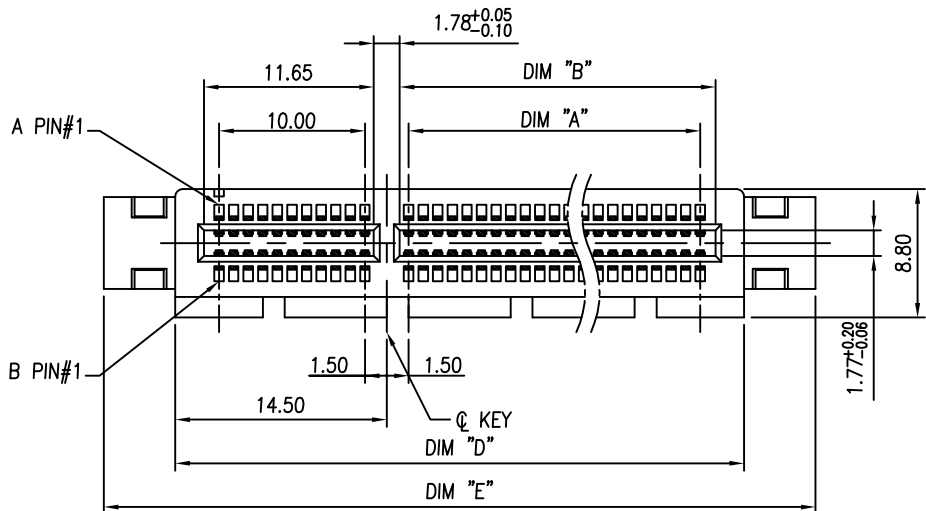

NOTES:

1. MATERIAL:
 - 1.1 HOUSING: THERMOPLASTIC, HIGH TEMP., UL94V-0; COLOR: BLACK.
 - 1.2 CONTACTS: COPPER ALLOY.
2. FINISH:
 - 2.1 CONTACT: SELECTIVE GOLD PLATING ON CONTACT AREA. 100μ" MIN. MATTE TIN PLATING ON SOLDER TAILS, 50μ" MIN. NICKEL UNDERPLATING OVERALL.
3. PRODUCT SPEC.: PS-3GIO-01

DIMENSIONS					
POSITION	A ±0.20	B ^{+0.15} / _{-0.05}	C ±0.20	D ±0.25	E ±0.30
36	6	7.65	12.30	25.00	34.8
64	20	21.65	26.30	39.00	48.8
98	37	38.65	43.30	56.00	65.8
164	70	71.65	76.30	89.00	98.8

REV	ECN NO.	NAME	DATE	TOLERANCE		UMax conn DONGGUAN UMAXCONN ENTERPRISE LIMITED	TITLE: PCI EXPRESS 1.0mm CARD EDGE ASSY', STRADDLE MOUNT TYPE						
				LINEAR	ANGLES		PART NO.	3126-10X0XX	DWG NO.	312607001	UNITS	SCALE	SHEET
E	10041	Terry	Jun,08,2011			APPD: Jason	MAT'L:						
D	10017	Terry	Apr,15,2010	X.±0.40	X'±	CHKD: Schumi	FINISH:						
C	09041	Terry	Jan,20,2009	.X±0.30	.X'±	DRWN: Terry	Q'TY:						
B	08048	Schumi	Aug,19,2008	.XX±0.20	.XX'±								
REV	ECN NO.	NAME	DATE	.XXX±0.10	.XXX'±								

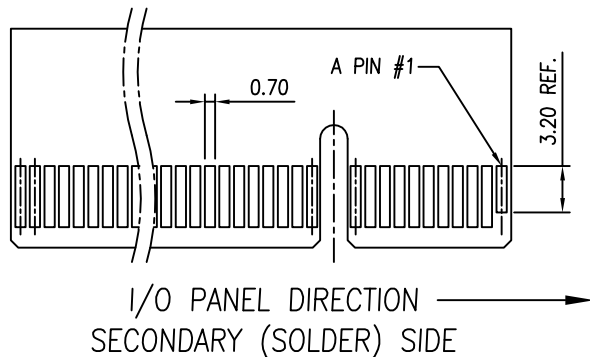
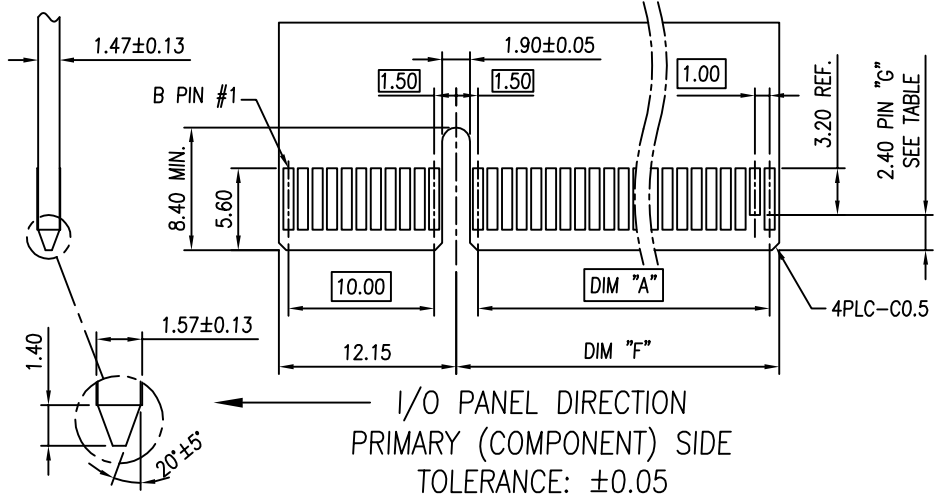

DIMENSIONS				
POSITION	DIM. A	DIM. C	DIM. F	PIN "G"
36	6	12.30	8.15	B PIN #B17
64	20	26.30	22.15	B PIN #B31
98	37	43.30	39.15	B PIN #B48
164	70	76.30	72.15	B PIN #B81



PART NO.

3126 - 10 X 0 X X

PCI EXPRESS Series No.

HSG Color

1: Black

TYPE

0: WITH MOUNTING EAR

Packing Options

T: Tray

D: Tray With Dummy Card

No. of Pins

0: 36P

1: 64P

2: 98P

3: 164P

Contact Plating

0: 30μ", Gold

1: 15μ", Gold

2: 1μ", Gold

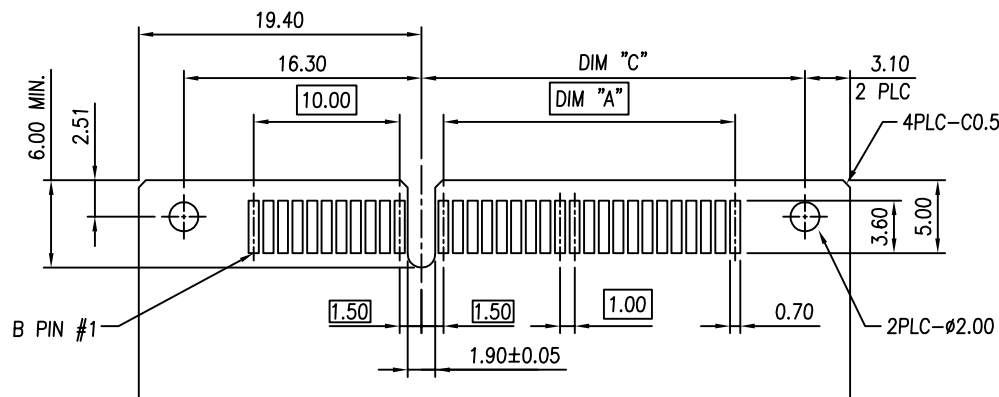

RECOMMENDED OF PCB DIMENSIONS

TOLERANCE: ±0.05

TOLERANCE		UMax conn DONGGUAN UMAXCONN ENTERPRISE LIMITED	TITLE: PCI EXPRESS 1.0mm CARD EDGE ASSY', STRADDLE MOUNT TYPE	
LINEAR	ANGLES		PART NO.	3126-10X0XX
X.	X'±	APPD: Jason	MAT'L:	DWG NO. 312607001
.X	.X'±	CHKD: Schumi	FINISH:	UNITS MM
.XX	.XX'±	DRWN: Terry	Q'TY:	SCALE 1 : 1
.XXX	.XXX'±			SHEET 2 OF 6

REV	ECN NO.	NAME	DATE
	See Sheet 1		

UNITS	SCALE	SHEET	REV
MM	1 : 1	2 OF 6	E

1 2 3 4 5 6 7 8

A

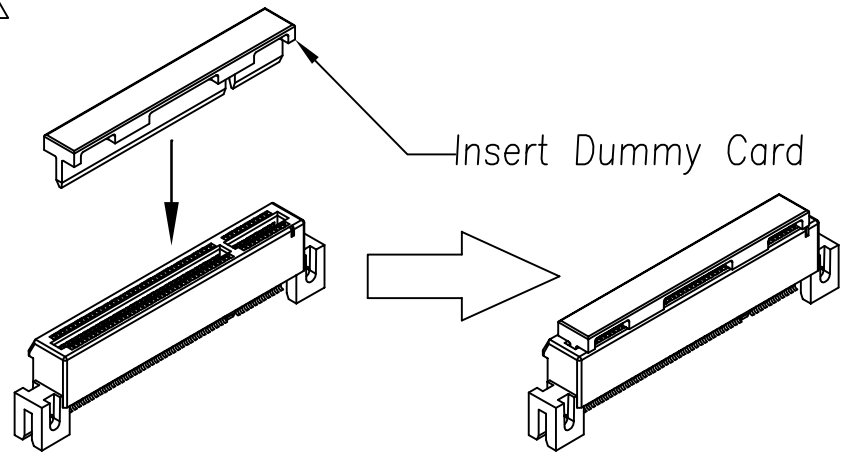
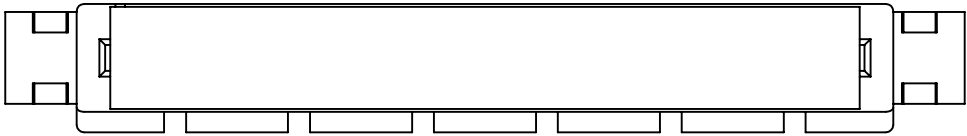

B

DIM "H"

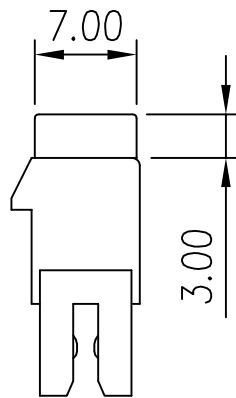
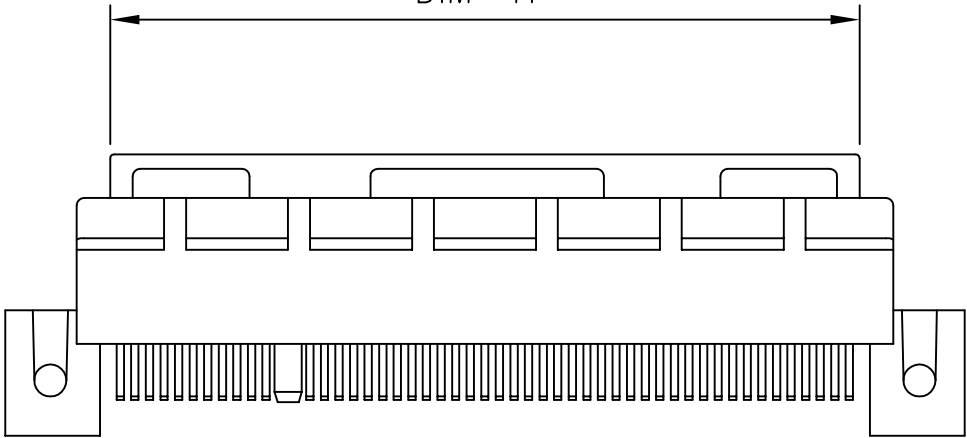

C

D

DIMENSIONS	
POSITION	DIM. H
36	20.4
64	34.4
98	51.4
164	84.4

TOLERANCE	
LINEAR	ANGLES
.X	.X°±
.X	.X°±
.XX	.XX°±
.XXX	.XXX°±

UMax conn 东莞市友贸实业有限公司 DONGGUAN UMAXCONN ENTERPRISE LIMITED	
APPD: Jason	MAT'L:
CHKD: Schumi	FINISH:
DRWN: Terry	Q'TY:

TITLE: PCI EXPRESS 1.0mm CARD EDGE ASSY', STRADDLE MOUNT TYPE			
PART NO. 3126-10X0X		DWG NO. 312607001	
UNITS	SCALE	SHEET	REV
MM	1 : 1	3 OF 6	E

See Sheet 1			
REV	ECN NO.	NAME	DATE

1 2 3 4 5 6 7 8 CUSTOMER