

NOTES :

1. MATERIAL :

INSULATOR : SUMIKASUPER LCP E6807

FLAMMABILITY RATING: UL94V-0

COLOR: IVORY

CONTACT : BRASS C2680R-H, t=0.30mm.

GROUND MOUNTING EAR: BRASS C2680R-H, t=0.20mm.

PICK-UP CAP:LCP E130i

2. PLATING :

CONTACT AREA: SELECTIVE GOLD (SEE P/N DESCRIPTION)

UNDER PLATING: 50u" Min. NICKEL OVERALL

SOLDER TAIL AREA: 100u" Min. TIN/LEAD or 100u" Min. MATTE TIN.

GROUND MOUNTING EAR CONTACT AREA: COLD FLASH.

GROUND MOUNTING EAR SOLDER AREA: 100u" Min. TIN/LEAD or 100u" Min. MATTE TIN.

3. SOLDER TAILS TO BE WITHIN 0.05 UPWARD AND 0.2 DOWNWARD FROM Z-DATUM PLACE, AND COPLANARITY OF SOLDER TAILS TO BE WITHIN 0.10mm.

4. PRODUCT SPEC: GS-12-240.

5. PACKAGING SPEC: GS-14-980.

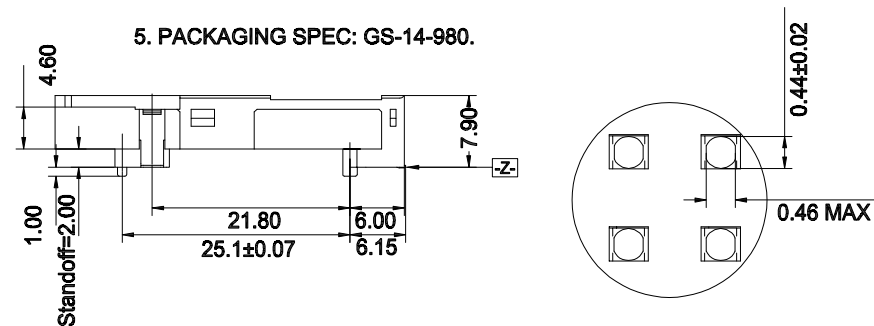

DETAIL A

NOTE: DIMENSIONAL MARK ∇ SHALL BE CHECKED BY O.Q.C.

PIN NUMBER	DIM. L±0.15
25,26	3.50
ALL OTHER PINS	4.25
1, 13, 38, 50	5.00

TOLERANCE		UMax 东莞市友贸实业有限公司 DONGGUAN UMAXCONN ENTERPRISE LIMITED	
LINEAR	ANGLES	APPD:	MAT'L:
X±0.40	X°±	Jason	
.X±0.30	.X°±	CHKD: Schumi	FINISH:
.XX±0.20	.XX°±	DRWN: Terry	Q'TY:
.XXX±0.10	.XXX°±		

TITLE: CF HEADER TYPE II NORMAL S/□=2.0			
PART NO.		CFH-4420LBMXXMNC	
DWG NO.		4420LBM07001	
UNITS	SCALE	SHEET	REV
MM	1 : 1	1 OF 2	A

REV	ECN NO.	NAME	DATE

6.Part Number Description:

P/N: CFH-4420LBM XX MNC

Contact Area Plating

01: Gold Flash

15: 15u" Gold

30: 30u" Gold

7. THIS PRODUCT MEETS THE EUROPEAN UNION DIRECTIVE AS DESCRIBED IN GS-22-008.

8. THIS PRODUCT MEETS THE EUROPEAN UNION DIRECTIVE AS DESCRIBED IN GS-22-008 EXCEPT FOR Pb.

9. THE HOUSING WILL WITHSTAND EXPOSURE TO 260°C PEAK TEMPERATURE FOR 10 SECONDS IN A CONVECTION, IR OR VAPER PHASE REFLOW OVEN.

10. THE PRODUCTS WHERE THE PART NUMBER ENDS IN "LF" MEET THE CRITERIA SHOWN IN THE NOTES 7 AND 9.

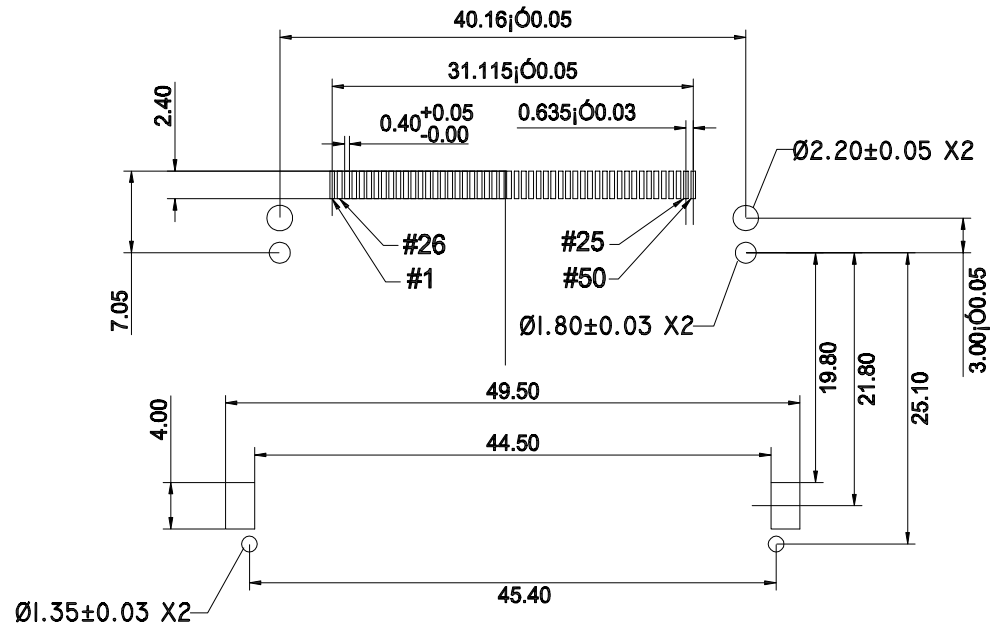

General Tolerance +/-0.05mm
Recommended PCB Pattern

				TOLERANCE		UMax conn 东莞市友贸实业有限公司 DONGGUAN UMAXCONN ENTERPRISE LIMITED		TITLE: CF HEADER TYPE II NORMAL S/D=2.0				
				LINEAR	ANGLES			PART NO. CFH-4420LBMXXMNC				
				X±0.40	X°±	APPD:	Jason	MAT'L:	DWG NO. 4420LBM07001			
				.X±0.30	.X°±	CHKD:	Schumi	FINISH:	UNITS	SCALE	SHEET	REV
				.XX±0.20	.XX°±	DRWN:	Terry	Q'TY:	MM	1 : 1	2 OF 2	A
REV	ECN NO.	NAME	DATE	.XXX±0.10	.XXX°±							