



# ORIENT

## Photo coupler

### Product Data Sheet

Part Number: OR-M302X/OR-M305X

Customer: \_\_\_\_\_

Date: \_\_\_\_\_

**SHENZHEN ORIENT COMPONENTS CO., LTD**

Block A 3rd Floor No.4 Building, Tian'an Cyber Park, Huangge Rd, LongGang Dist, Shenzhen, GD

TEL: 0755-29681816

FAX: 0755-29681200

[www.orient-opto.com](http://www.orient-opto.com)

**1. Features**

- (1) High isolation voltage between input and output (Viso:3750 V rms )
- (2) 4pin non zero-cross optoisolators triac driver output
- (3) High repetitive peak off-state voltage VDRM :  
302X: Max. 400V , 305X: Max. 600V
- (4) High critical rate of rise of off-state voltage dv/dt :  
302X: Typ. 10V / s , 305X:MIN. 1000V / s
- (5) Tape and reel packaging.
- (6) Operating temperature -40 °Cto +110 °C
- (7) Safety approval  
UL approved(No.E323844)  
VDE approved(No.40029733)  
CQC approved (No.CQC09001029446 )
- (8) In compliance with RoHS, REACH standards
- (9) MSL Class I



**2. Description**

The OR-M302X,OR-M305X consists of a non zero crossing photo triac, optically coupled to a gallium arsenide infrared emitting diode. They are housed in the SOP-4 package and guarantees insulation thickness. Therefore, they meet the reinforced insulation class requirements of international safety standards.

**3. Application Range**

- AC Motor Drives
- AC Motor Starters
- Static power switch
- Lighting Controls
- Solenoid/Valve Controls
- Solid State Relays
- Temperature Controls

**4. Functional Diagram**

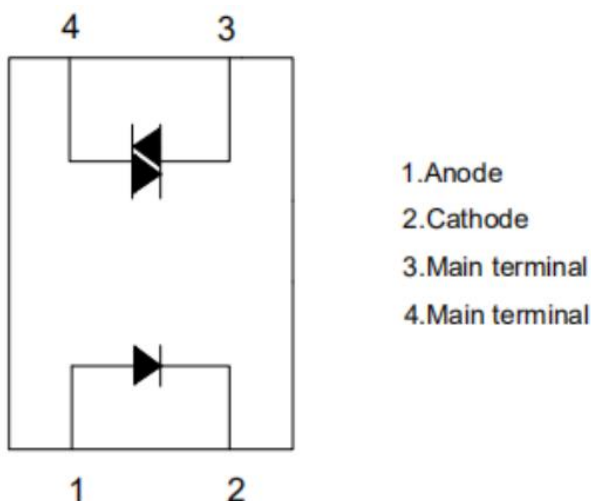

**5. Absolute Maximum Ratings (Ta=25°C)**

Parameter		Symbol	Rated Value	Unit	
Input	Forward Current	$I_F$	50	mA	
	Junction Temperature	$T_J$	125	°C	
	Reverse Voltage	$V_R$	6	V	
	Power Dissipation	P	100	mW	
Output	Off-State Output Terminal Voltage	OR-M302X	$V_{DRM}$	400	V
		OR-M305X		600	
	On state RMS current	$I_{T(RMS)}$	100	mA(RMS)	
	Peak Repetitive Surge Current (PW=1ms, 120 pps)	$I_{TSM}$	1	A	
	Junction Temperature	$T_J$	125	°C	
	Collector Power Dissipation	$P_C$	300	mW	
	Total Power Dissipation	$P_{tot}$	330	mW	
*1 Insulation Voltage	$V_{iso}$	3750	Vrms		
Working Temperature	$T_{opr}$	-40 ~ + 110	°C		
Deposit Temperature	$T_{stg}$	-55 ~ + 125			
*2 Soldering Temperature	$T_{sol}$	260			

Notes:

\*1 AC for 1 minute, R.H.= 40 ~ 60% R.H. In this test, pins 1, 2&3 are shorted together, and pins 4, 6 are shorted together.

\* 2 For 10 seconds

**6. Electrical Optical Characteristics at Ta=25°C**

Parameter		Symbol	Min	Typ.*	Max	Unit	Condition	
Input	Forward Voltage	$V_F$	---	1.2	1.6	V	$I_F=10\text{mA}$	
	Reverse Current	$I_R$	---	---	5	$\mu\text{A}$	$V_R=6\text{V}$	
Output	*1.Peak Blocking Current, Either Direction	$I_{\text{DRM}}$	---	10	100	nA	$V_{\text{DRM}} = \text{Rated } V_{\text{DRM}}$	
	Peak On-State Voltage, Either Direction	$V_{\text{TM}}$	---	---	2.5	V	$I_{\text{TM}}=100\text{mA}$ Peak	
	*2.Critical rate of Rise of Off-State Voltage	OR-M302X	$dv/dt$	---	10	---	$\text{V}/\mu\text{s}$	$V_{\text{in}}=240\text{V}_{\text{rms}}$
OR-M305X		1000		---	---			
Transfer Characteristics	*3.Led Trigger Current, Current Required to Latch Output, Either Direction	OR-M3020 OR-M3050	$I_{\text{FT}}$	---	---	30	mA	Main Terminal Voltage = 3V
		OR-M3021 OR-M3051		---	---	15		
		OR-M3022 OR-M3052		---	---	10		
		OR-M3023 OR-M3053		---	---	5		
		OR-M3024 OR-M3054		---	---	3		
	Holding Current, Either Direction		$I_H$	---	3	5	mA	
	Turn-On Time		$T_{\text{on}}$	---	---	100	$\mu\text{s}$	$V_D=6\text{V}$ $R_L=100\Omega$ $I_F=20\text{mA}$

\*1. Test voltage must be applied within  $dv/dt$  rating.

\*2. This is static  $dv/dt$ . Commutating  $dv/dt$  is a function of the load-driving thyristor(s) only.

\*3. All devices are guaranteed to trigger at an  $I_F$  value less than or equal to max  $I_{\text{FT}}$ . Therefore, recommended operating  $I_F$  lies between max  $I_{\text{FT}}$ , 30 mA for OR-M3020 and OR-M3050, 15 mA for OR-M3021 and OR-M3051, 10 mA for OR-M3022 and OR-M3052, 5 mA for OR-M3023 and OR-M3053, 3 mA for OR-M3024 and OR-M3054, and absolute max  $I_F$  (50mA).



## 7. Order Information

Part Number

**OR-M302X-W-Y-Z**

Or **OR-M305X-W-Y-Z**

Note

X = Part Number(0,1,2,3 or 4)

W = Tape and reel option (TP or TP1).

Y = 'V' code for VDE safety (This options is not necessary).

Z = 'G' code for Halogen free.

\* VDE Code can be selected.

Option	Description	Packing quantity
TP	Surface mount lead form (low profile) + TP tape & reel option	3000 units per reel
TP1	Surface mount lead form (low profile) + TP1 tape & reel option	3000 units per reel

### 8. Naming Rule

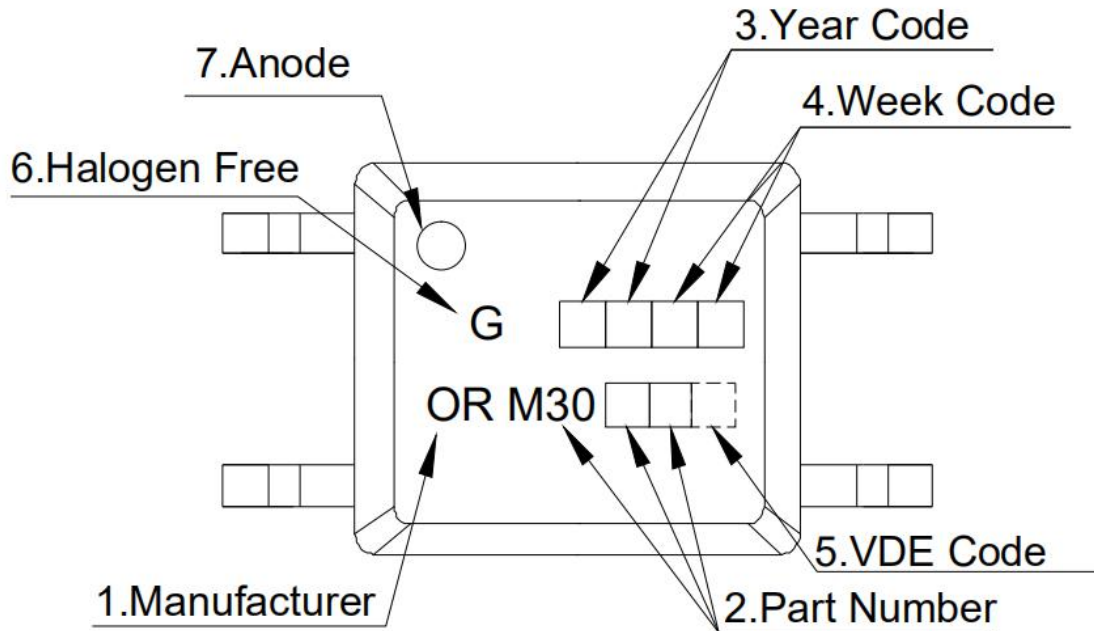

1. Manufacturer : ORIENT.
2. Part Number : M30□□.
3. Year Code □□ : '21' means '2021' and so on.
4. Week Code □□: 01 means the first week, 02 means the second week and so on.
5. VDE Code □.
6. HF Code 'G': Halogen Free.
7. Anode.

\* VDE Code can be selected.

### 9. Package Dimension

OR-M30XX

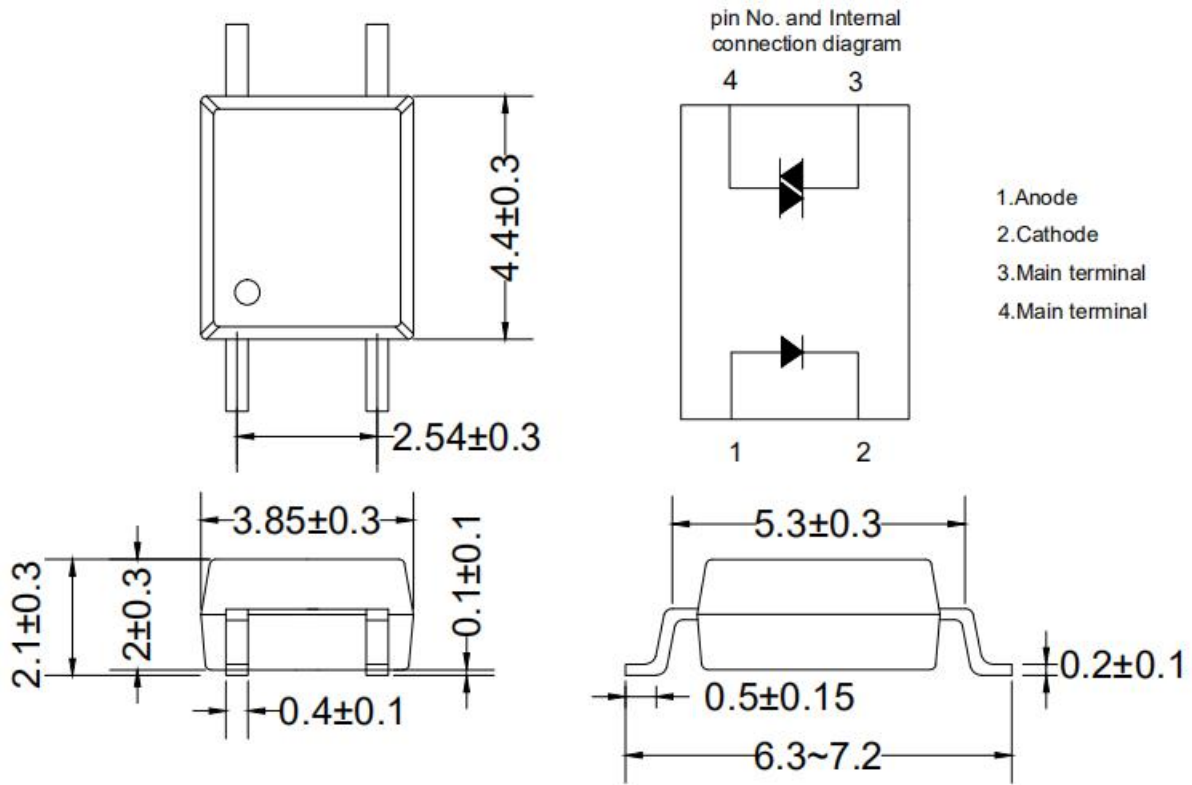

### 10. Recommended Foot Print Patterns (Mount Pad)

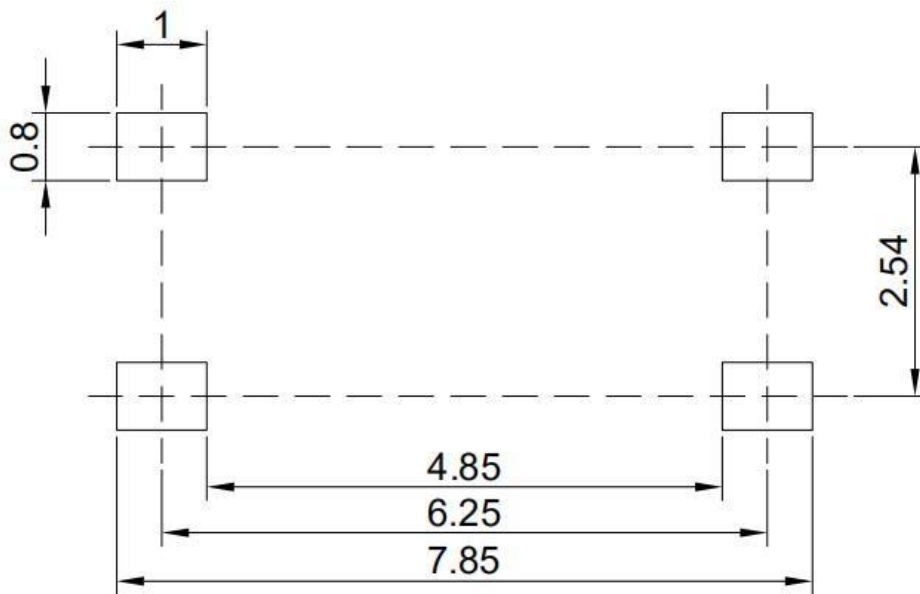

unit: mm

### 11. Taping Dimensions

(1)OR-M30XX-TP

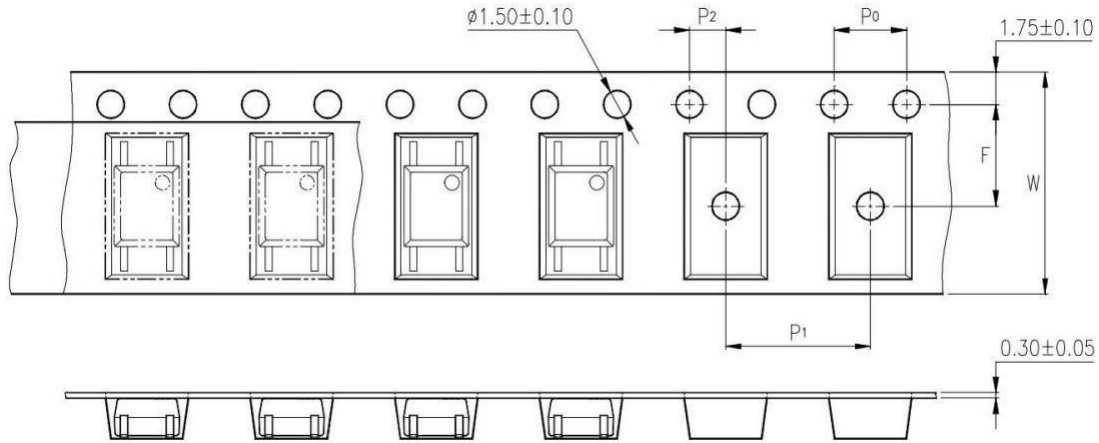

(2)OR-M30XX-TP1

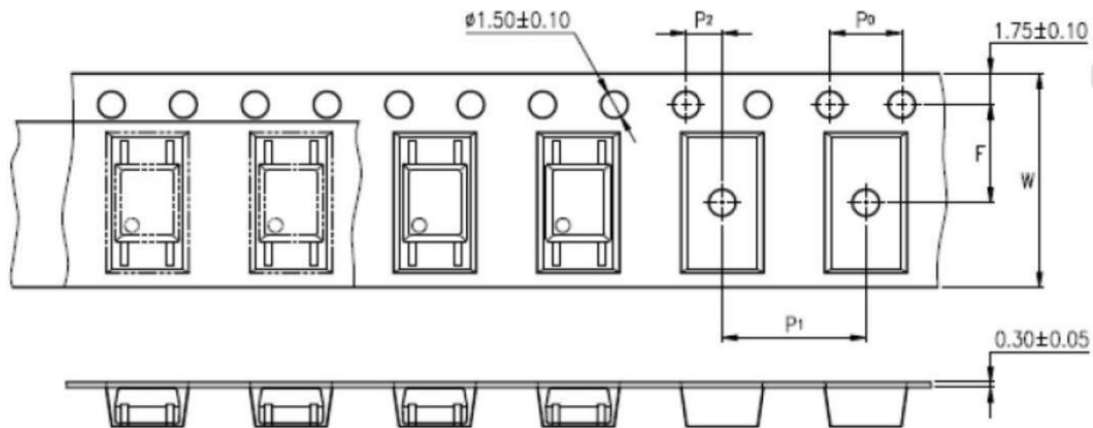

Description	Symbol	Dimension in mm (inch)
Tape wide	W	12±0.3 (0.472)
Pitch of sprocket holes	P0	4±0.1 (0.157)
Distance of compartment	F	5.5±0.1 (0.217)
	P2	2±0.1 (0.079)
Distance of compartment to compartment	P1	8±0.1 (0.315)

Package Type	TP/TP1
Quantities(pcs)	3000



## 12. Package Dimension

### (1) package dimension

Packing Information	
Packing type	Reel type
Tape Width	12mm
Qty per Reel	3,000pcs
Small box (inner) Dimension	345*345*45mm
Large box (Outer) Dimension	480x360x360mm
Max qty per small box	6,000pcs
Max qty per large box	60,000pcs

### (2)Packing Label Sample



#### Note:

1. P/N :Contents with "Order Information" in the specification.
2. LOT NO : The production lot.
3. BATCH : The Electrical rank.
4. Quantity :Packaging quantity.
5. Product Data :Date of manufacture.

### 13. Temperature Profile Of Soldering

(1) IR Reflow soldering (JEDEC-STD-020C compliant)

One time soldering reflow is recommended within the condition of temperature and time profile shown below. Do not solder more than three times.

Profile item	Conditions
Preheat	
- Temperature Min (T Smin )	150°C
- Temperature Max (T Smax )	200°C
- Time (min to max) (ts)	90±30 sec
Soldering zone	
- Temperature (TL )	217°C
- Time (t L )	60 sec
Peak Temperature	260°C
Peak Temperature time	20 sec
Ramp-up rate	3°C / sec max.
Ramp-down rate from peak temperature	3~6°C / sec
Reflow times	≤3

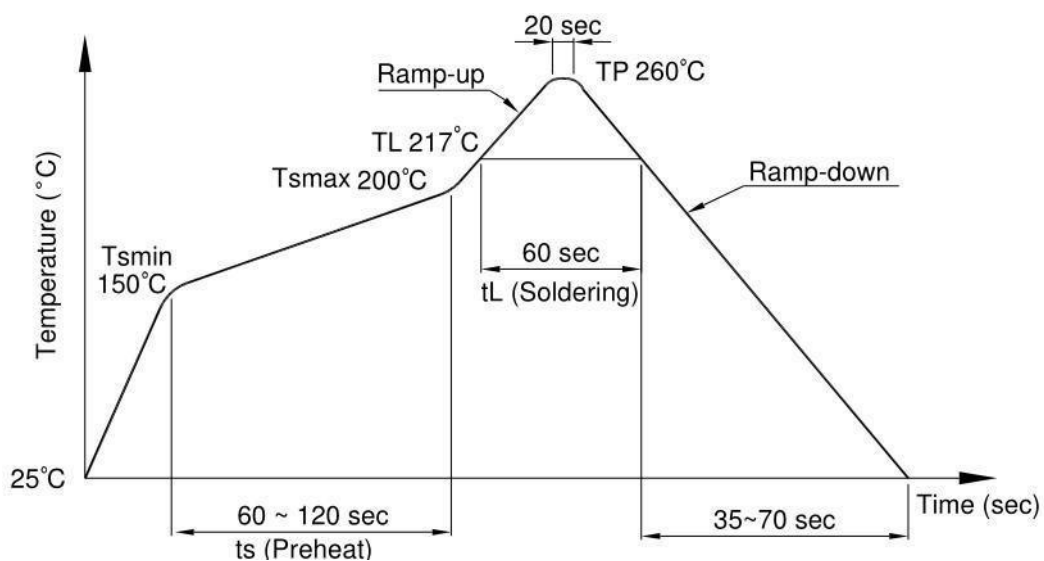

(2) Wave soldering (JEDEC22A111 compliant)

One time soldering is recommended within the condition of temperature.

Temperature	260+0/-5°C
Time	10 sec
Preheat temperature	5 to 140°C
Preheat time	30 to 80 sec

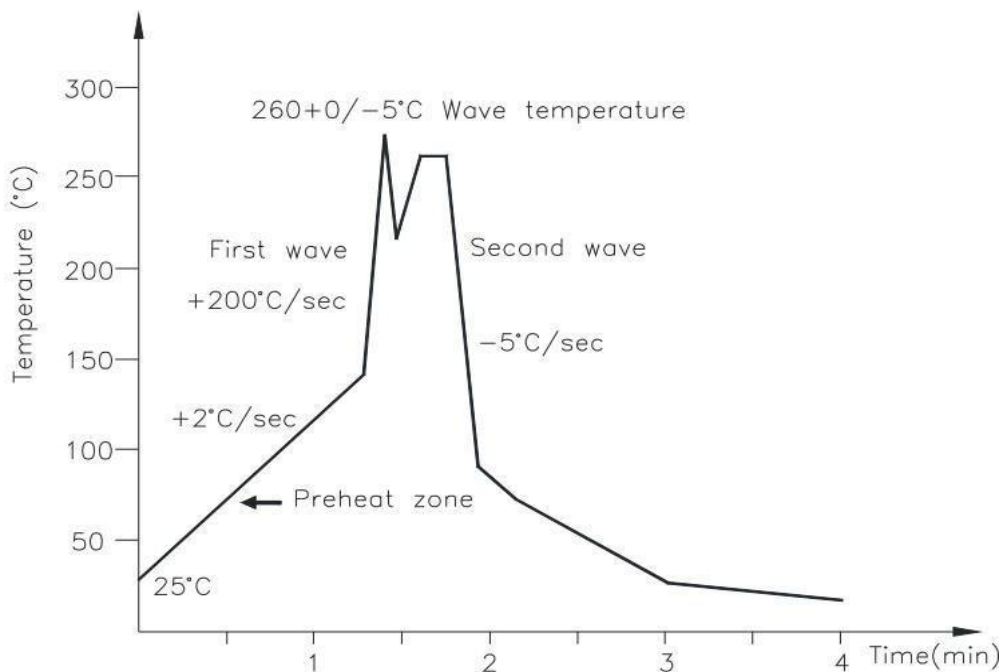

(3) Hand soldering by soldering iron

Allow single lead soldering in every single process. One time soldering is recommended.

Temperature	380+0/-5°C
Time	3 sec max

14. CHARACTERISTICS CURVES (TYPICAL PERFORMANCE)

Fig.1 Forward current vs Ambient temperature

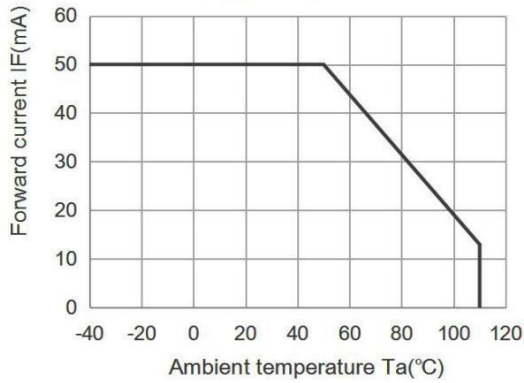

Fig.2 On-state current vs. Ambient temperature

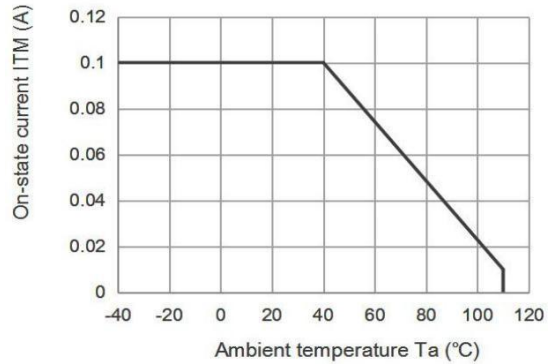

Fig.3 Minimum Trigger Current vs. Ambient temperature

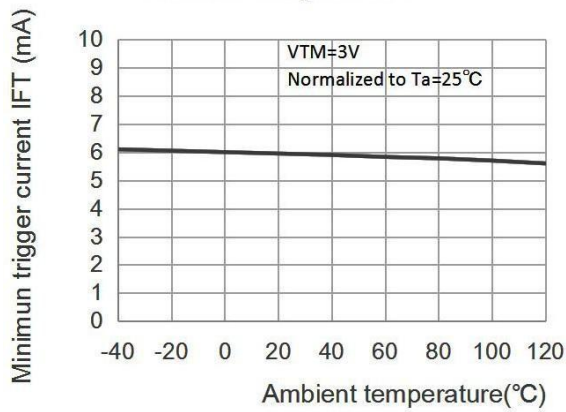

Fig.4 Forward current vs. Forward voltage

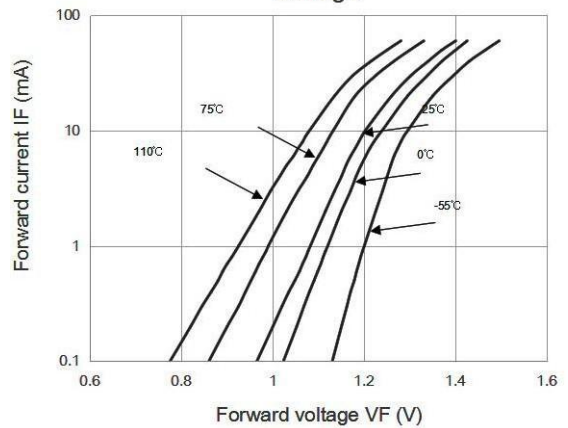

Fig.5 On-state voltage vs. Ambientn temperature

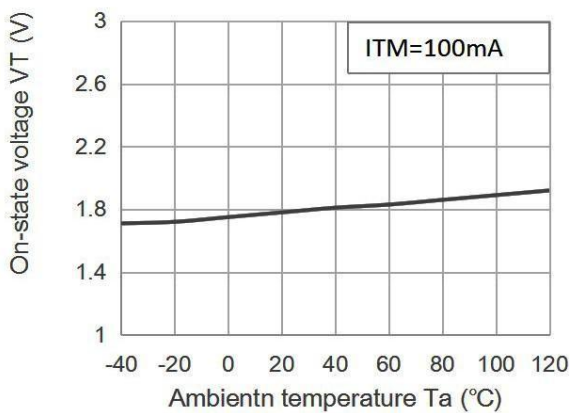

Fig.6 Holding current vs. Ambient temperature

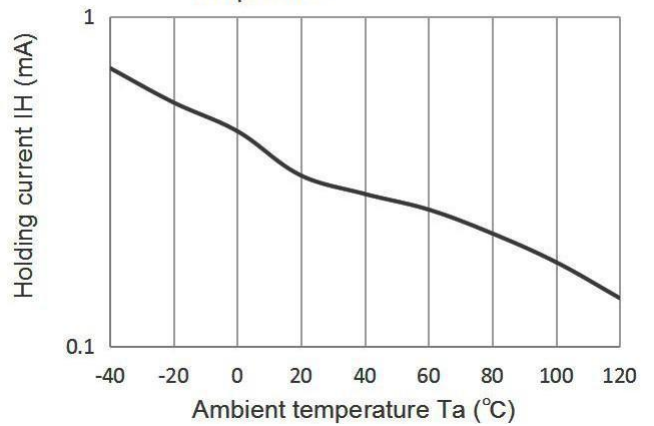

Fig.7 Repetitive peak off-state current vs. Temperature

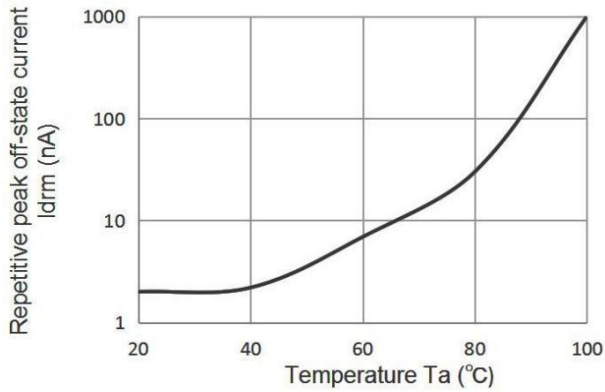

Fig.8 On-state current vs. On-state voltage

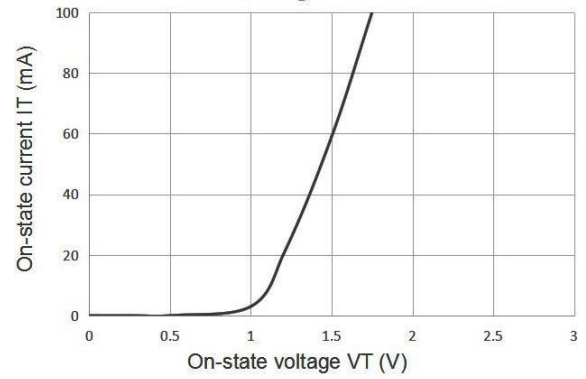

Fig9. Basic Operation Circuit Medium/High Power Triac Drive Circuit

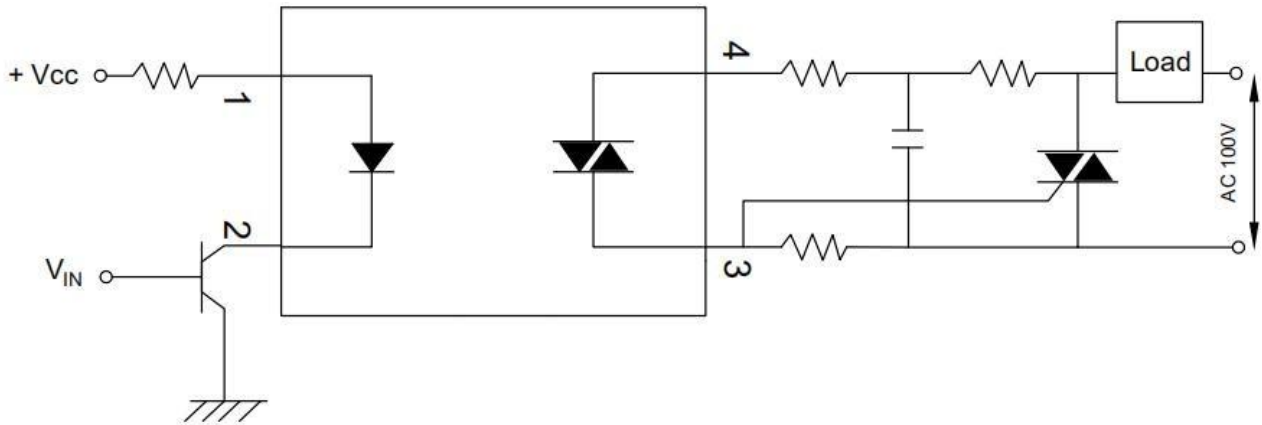
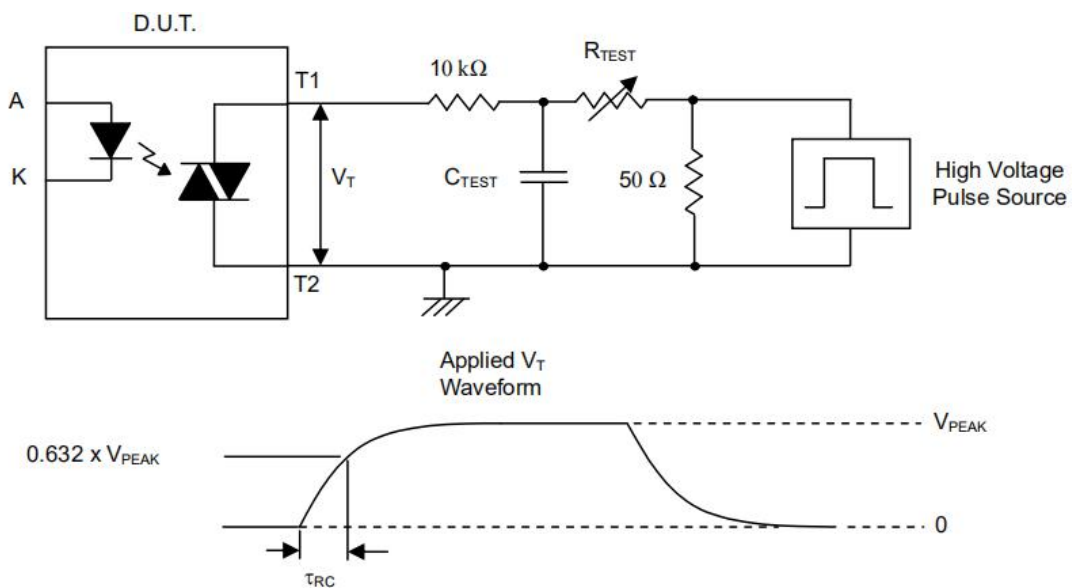

Fig10. Static dv/dt Test Circuit & Waveform



## Measurement Method

The high voltage pulse is set to the required  $V_{PEAK}$  value and applied to the D.U.T. output side through the RC circuit above. LED current is not applied. The waveform  $V_T$  is monitored using a x100 scope probe. By varying  $R_{TEST}$ , the  $dv/dt$  (slope) is increased, until the D.U.T. is observed to trigger (waveform collapses). The  $dv/dt$  is then decreased until the D.U.T. stops triggering. At this point,  $\tau_{RC}$  is recorded and the  $dv/dt$  calculated.

$$dv/dt = \frac{0.632 \times V_{PEAK}}{\tau_{RC}}$$

$$dv/dt = \frac{0.632 \times V_{PEAK}}{\tau_{RC}}$$

For example,  $V_{PEAK} = 600V$  for EL306X series. The  $dv/dt$  value is calculated as follows:

$$dv/dt = \frac{0.63 \times 600}{\tau_{RC}} = \frac{378}{\tau_{RC}}$$